

European Technical Assessment

ETA 13/0384

Version 01

Date of issue: 2018-06-21



UBA_tc Assessment Operator:
Belgian Construction Certification Association
Rue d'Arton 53 - 1040 Brussels
www.bcca.be - info@bcca.be



Technical Assessment Body issuing the European Technical Assessment: UBA_tc.
UBA_tc has been designated according to Article 29 of Regulation (EU) No 305/2011
and is member of EOTA (European Organisation for Technical Assessment)

Trade name of the construction product:

Green Isologic EU, Green Isologic LE, Green Isologic PA & Green Isologic ZE

Product family to which the construction product belongs:

Non load-bearing permanent shuttering kits based on panels made of EPS

Manufacturer:

Green Isologic s.p.r.l.
49 Rue Slar
4801 Stembert
Belgium

Manufacturing plants:

Seuropak bvba
Nijverheidslaan, 10
8560 Gullegem
Belgium

Website:

www.GreenIsologic.be

This European Technical Assessment is issued in accordance with Regulation (EU) No 305/2011, on the basis of:

ETA-Guideline 009, used as European Assessment Document (EAD)

This version replaces:

ETA 13/0384 valid from 30/06/2013 until 29/06/2018.

This European Technical Assessment contains:

23 pages, including 2 annexes, which form an integral part of this ETA.



European Organisation for Technical Assessment

Legal bases and general conditions

- 1 This European Technical Assessment is issued by UBAtc (Union belge pour l'Agrément technique de la construction, i.e. Belgian Union for technical Approval in construction), in accordance with:
 - Regulation (EU) N° 305/2011¹ of the European Parliament and of the Council of 9 March 2011 laying down harmonised conditions for the marketing of construction products and repealing Council Directive 89/106/EEC
 - Commission Implementing Regulation (EU) N° 1062/2013² of 30 October 2013 on the format of the European Technical Assessment for construction products
 - ETA-Guideline 009, used as European Assessment Document (EAD).
- 2 Under the provisions of Regulation (EU) No 305/2011, UBAtc is not authorized to check whether the provisions of this European Technical Assessment are met once the ETA has been issued.
- 3 The responsibility for the conformity of the performances of the products with this European Technical Assessment and the suitability of the products for the intended use remains with the holder of the European Technical Assessment.
- 4 Depending on the applicable Assessment and verification of constancy of performance (AVCP) system, (a) notified body(ies) may carry out third-party tasks in the process of assessment and verification of constancy of performance under this Regulation once the European Technical Assessment has been issued.
- 5 This European Technical Assessment allows the manufacturer of the construction product covered by this ETA to draw up a declaration of performance for the construction product.
- 6 CE marking should be affixed to all construction products for which the manufacturer has drawn up a declaration of performance.
- 7 This European Technical Assessment is not to be transferred to other manufacturers, agents of manufacturers, or manufacturing plants other than those indicated on page 1 of this European Technical Assessment.
- 8 The European Technical Assessment holder confirms to guarantee that the product(-s) to which this assessment relates, is/are produced and marketed in accordance with and comply with all applicable legal and regulatory provisions, including, without limitation, national and European legislation on the safety of products and services. The ETA-holder shall notify the UBAtc immediately in writing of any circumstance affecting the aforementioned guarantee. This assessment is issued under the condition that the aforementioned guarantee by the ETA-holder will be continuously observed.
- 9 According to Article 11(6) of Regulation (EU) N° 305/2011, when making a construction product available on the market, the manufacturer shall ensure that the product is accompanied by instructions and safety information in a language determined by the Member State concerned which can be easily understood by users. These instructions and safety information should fully correspond with the technical information about the product and its intended use, which the manufacturer has submitted to the responsible Technical Assessment Body for the issuing of the European Technical Assessment.
- 10 Pursuant to Article 11(3) of Regulation (EU) N° 305/2011, manufacturers shall adequately take into account changes in the product-type and in the applicable harmonised technical specifications. Therefore, when the contents of the issued European Technical Assessment do not any longer correspond to the product-type, the manufacturer should refrain from using this European Technical Assessment as the basis for their declaration of performance.
- 11 All rights of exploitation in any form and by any means of this European Technical Assessment is reserved for UBAtc and the ETA-holder, subject to the provisions of the applicable UBAtc regulations.
- 12 Reproduction of this European Technical Assessment including transmission by electronic means shall be in full. However, partial reproduction can be made with the written consent of UBAtc. In this case partial reproduction has to be designated as such. Texts and drawings of advertising brochures shall not contradict or misuse the European Technical Assessment.
- 13 Subject to the application introduced, this European Technical Assessment is issued in English and may be issued by the UBAtc in its official languages. The translations correspond fully to the English reference version circulated in EOTA.
- 14 This European Technical Assessment was first issued by UBAtc on 21 June 2018 and comprises no technical modifications compared with the European Technical Approval, which was valid from 30/06/2013 until 29/06/2018. However, the name of the ETA-holder and the trade name of the products covered have been modified.

¹ OJEU, L 88 of 2011/04/04

² OJEU, L 289 of 2013/10/31

Technical Provisions

1 Technical description of the product

1.1 Characteristics of the products

1.1.1 General

Green Isologic is a non-loadbearing permanent shuttering system based on hollow blocks made of expanded polystyrene (EPS) leaves and polypropylene spacers applicable as formwork for plain and reinforced concrete walls cast in-situ.

The concrete infill structural pattern is of continuous type.

All details about shape and dimensions of the shuttering elements are given in this ETA, Annex 1.

Special elements as lintel, corner and closing element are also part of this ETA.

Renderings, coatings and plasterboards are not part of this ETA.

2 Specification of the intended use(s) in accordance with the applicable EAD

2.1 General

The provisions made in this European Technical Assessment are based on an assumed intended working life of 50 years, provided that the assembled product is subject to appropriate use and maintenance, in accordance with this ETA.

Indications given regarding the working life cannot be interpreted as a guarantee given by the producer or the UBA^tc, but are to be regarded only as a means for choosing the appropriate product(s) in relation to the expected economically reasonable working life of the construction works.

2.2 Intended uses

The kit is intended to be used for construction of load-bearing (structural) or non-load-bearing (non-structural) external (below or above ground) and internal walls for residential and non-residential buildings, including those, which are subject to fire regulations.

When using this type of construction below ground a waterproofing according to applicable national rules shall be provided.

The relevant and applicable use categories in accordance with EOTA TR 034 for the product are:

- Category IA2: product with no direct contact but possible impact on indoor air
- Category S/W 3: product with no contact to and no impact on soil, ground or surface water.

2.3 Provisions related to manufacturing, packaging and storage

The wall kit is applied on site according to the procedure laid down in the technical file deposited with the UBA^tc.

2.4 Packaging, transportation, storage, installation, maintenance, replacement and repair

Concerning product packaging, transport, storage, installation, maintenance, replacement and repair it is the responsibility of the manufacturer to undertake the appropriate measures and to advise his clients on the transport, storage, installation, maintenance, replacement and repair of the product, as he considers necessary.

It is assumed that the kit will be installed according to the manufacturer's instructions or (in absence of such instructions) according to the usual practice of the building professionals.

2.5 Provisions related to the design and use of the product

The installation instructions, including special installation techniques and provisions for the qualification of the personnel are given in the manufacturer's technical documentation.

3 Performance of the product and references to the methods used for its assessment

3.1 Essential characteristics

3.1.1 Shuttering leaves

The shuttering leaves are made of expanded polystyrene. They are in conformity with EN 13163.

Table 1 - Thicknesses of the shuttering leaves

	Inner shuttering leaf	Outer shuttering leaf
Green Isologic EU	50	50
Green Isologic LE		100
Green Isologic PA		150
Green Isologic ZE		200

The upper and lower surfaces of the shuttering leaves are castellated and the vertical mating surfaces are tongue and mortise to form a tight fit when joined together.

Table 2 - Characteristics of EPS

Characteristics	Unity	Value
nominal density	kg/m ³	31
thermal conductivity $\lambda_{90/90}$	W/mK	0,031
water vapour diffusion resistance	-	60
Reaction to fire	Euroclass	NPA*
* No performance assessed		

The inner and outer surfaces have grooves running vertically. Those grooves on the outer side allow the application of hydraulic coatings. Because of the grooves on the inner side, the concrete combines with the shuttering leaves in a perfect fit. The grooves on the inner side also form locks for end stops.

3.1.2 Spacers

The spacers are made from polypropylene.

The horizontal distance between the spacers is 200 mm (see this ETA, Annex 1).

The shape of the spacers makes them suitable for precise location of the reinforcement bars for the concrete and secure a correct position of the reinforcement.

The two ends of the spacers are embedded in the EPS of the shuttering leaves.

The sum of the cross-sectional areas of the spacers is less than 2% of the area of the concrete core.

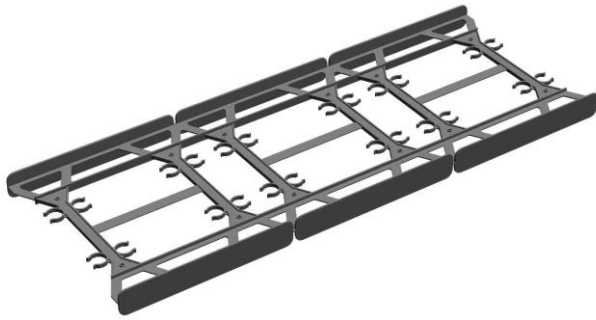

3.1.3 Shuttering elements

The length of the shuttering elements is 1200 mm and the height is 600 mm (see this ETA, Annex 1).

3.1.4 Mechanical resistance and stability

3.1.4.1 Resulting structural pattern

The structural pattern is of continuous type according to ETAG 009.

The dimensions and shape of the blocks are given in this ETA, Annex 1.

3.1.4.2 Efficiency of filling

The efficiency of filling was verified by erection of a trial structure in-situ.

Considering the instructions of this ETA, clause 4.2, and the installation guide of the ETA-holder the efficient filling without bursting of the shuttering and without voids or any uncovered reinforcement in the concrete core is possible.

3.1.4.3 Possibility of steel reinforcements

The instructions of the installation guide of the ETA-holder are appropriate to incorporate reinforcements in the walls, in accordance with EN 1992-1-1 or with equivalent national calculation rules.

Green Isologic recommends using of reinforced concrete steel fibers of the type Dramix QPC.

3.1.5 Safety in case of fire

3.1.5.1 Reaction to fire

No performance assessed.

3.1.5.2 Resistance to fire

With a minimum thickness of the continuous concrete core of 150 mm and minimum concrete strength C16/20 according to ETAG 009, Annex C, the resistance to fire of wall is as follows:

- Load-bearing wall: REI120
- Non load-bearing wall: EI120

3.1.6 Hygiene, health and the environment

3.1.6.1 Release of dangerous substances

The manufacturer provided a statement, confirming that the raw material of Green Isologic system contains flame retardant hexabromocyclododecane (HBCDD), which has been classified as dangerous according to General ER3 Checklist and listed in the "indicative list on dangerous substances".

The content of hexabromocyclododecane is $\leq 2,0\%$ w/w.

3.1.6.2 Water vapour permeability

The tabulated design value of water vapour diffusion resistance coefficient (μ) of expanded polystyrene, in accordance with EN ISO 10456 is 60.

The values for the water vapour diffusion resistance of concrete in dependence of density and type are tabulated in EN ISO 10456.

Based on calculations according to EN ISO 13788 using normal climatic boundary conditions, the kit's external envelope has been assessed to provide adequate moisture control for the intended use, provided that the building is heated during winter time.

3.1.6.3 Water absorption

No adverse reaction caused by the capillarity of the shuttering leaves was observed during the filling assessment.

3.1.6.4 Water tightness

Wall finishes (internal and external) are not part of the kit.

According to the installation guide of the ETA-holder, when this type of construction is used below ground an adequate waterproofing shall be provided.

For internal protection (in rooms with splashing water and/or high humidity), the recommendations of the ETA-holder shall be followed.

3.1.7 Safety in use

3.1.7.1 Resistance to filling pressure

The resistance to filling pressure has been determined by testing the tensile strength of the spacers and the pull-out strength between spacers and shuttering leaves.

The minimal tensile strength of the spacer is 4140 N. The minimal pull-out strength between spacers and shuttering leaves is 2631 N.

Resistance to filling pressure is satisfactory for filling to 1 m high at once (at an average vertical concreting rate of 1,6 m/h) without bracing supports and to 2,40 m (storey's height) with bracing supports.

The maximum aggregate size shall be 16 mm and the slump class of the concrete shall be S4 according to EN 206-1:2013, Table 3. The concrete shall have rapid or middle strength development according to EN 206-1:2013, Table 12.

Table 3 - Resistance to filling pressure

Characteristics	Unity	Value
Minimal tensile strength of the spacers	kN	4,14
Minimal strength to pull out of the spacers	kN	2,63
maximum pouring height without bracing supports	m	1

In addition, the resistance to filling pressure was verified by erection of a trial structure in-situ. The resistance to filling pressure has been controlled during filling and on completion of the filling. The requirements in respect to cracking and failure of the system elements and horizontal bowing of shuttering are satisfactorily met.

Requirements of ETAG 009, clause 6.4.2, have been satisfied.

3.1.7.2 Safety against personal injury by contact

The shuttering elements do not have sharp or cutting edges, even if they were cut out for the realization of the particular points of construction. The surface of the shuttering leaves is soft. There is no risk of abrasion or of cutting injuries.

3.1.7.3 Impact resistance

The wall finishes are not part of the kit. No impact resistance based on impact tests has been assessed.

3.1.8 Protection against noise

3.1.8.1 Airborne sound insulation

Airborne sound insulation has been measured according to EN ISO 10140-2.

Table 4 - Sound reduction index - laboratory results

	R_w(C;C_{tr}) dB
Green Isologic EU	53(-4;-3)
Green Isologic PA + gypsum board (12.5mm)	50(-1;-4)
Green Isologic ZE	49(-1;-4)
Green Isologic ZE + gypsum board (12.5mm)	46(0;-3)
Green Isologic ZE + external render	50(-2;-5)

3.1.8.2 Sound absorption

No performance assessed.

3.1.9 Energy and heat retention

3.1.9.1 Thermal resistance

The values of thermal resistance R_T and the corresponding thermal transmittance coefficient U of the shuttering elements in end use conditions (with concrete filling but without inner and outer finishes) are given in this ETA, Table 5. The calculation is carried out in accordance with EN ISO 6946 taking into account a thermal conductivity of 0.031 W/mK for the EPS and of 2 W/mK for concrete.

Table 5 - Thermal resistance

Product	Thickness [mm]			R _T [m ² K/W]	U [W/ m ² K]
	Internal shuttering leaf	Concrete core	External shuttering leaf		
Green Isologic EU			50	3,47	0,29
Green Isologic LE			100	5,08	0,20
Green Isologic PA	50	150	150	6,69	0,15
Green Isologic ZE			200	8,31	0,12

NOTE: The values R_{s1} and R_{se} used to determined RT are respectively 0,125 m²K/W and 0,043 m²K/W

3.1.9.2 Thermal inertia

The values of the heat capacity of concrete and expanded polystyrene are tabulated in EN ISO 10456.

3.1.10 Aspects of durability, serviceability and identification

3.1.10.1 Resistance to deterioration

3.1.10.1.1 Physical agents

The dimensional variations of the expanded polystyrene under the effect of one exposure to the temperature of 70°C during 48 hours are lower than 3%.

3.1.10.1.2 Chemical agents

Green Isologic shuttering elements do not contain any steel components and no corrosion can occur. Expanded polystyrene is chemically inert and would only be at risk from petrol or diesel or similar solvents. Wall finishes (internal and external) are not part of the kit. No performance assessed.

3.1.10.1.3 Biological agents

The application of EPS as thermal insulating material for decades has shown that it sufficiently protects against fungi, bacteria, algae and insects.

EPS does not provide a food value and in general it does not contain voids suitable for habitation by vermin.

The product does not contain any biocide.

3.1.10.2 Resistance to normal use damage

The product will be protected in use by internal finishing and external applications against normal use impacts.

The instructions given in the installation guide of the ETA-holder are suitable for the realization of perforations through the walls to make pass ducts.

The installation guide of the ETA-holder regarding fixings (hanging objects) shall be followed.

4 Assessment and verification of constancy of performance (AVCP) system applied, with reference to its legal base

In accordance with Regulation (EU) N° 305/2011, Article 65, Directive 89/106/EEC is repealed, but references to the repealed Directive shall be construed as references to the Regulation.

According to the European Commission Decision 98/279/EC, as amended by 2001/596/EC, system 2+ of attestation of conformity applies.

5 Technical details necessary for the implementation of the AVCP system

5.1 Tasks for the ETA-holder

5.1.1 Factory production control (FPC)

5.1.1.1 General

The manufacturer shall establish, document and maintain a FPC system to ensure that the products placed on the market conform to the stated performance characteristics. The FPC system shall consist of procedures, regular inspections and tests and/or assessments and the use of the results to control raw and other incoming materials or components, equipment, the production process and the product.

A FPC system conforming with the requirements of EN ISO 9001, and made specific to the requirements of this ETA, is considered to satisfy the above requirements.

The results of inspections, tests or assessments requiring action shall be recorded, as shall any action taken. The action to be taken when control values or criteria are not met shall be recorded.

5.1.1.2 Equipment

All weighing, measuring and testing equipment shall be calibrated and regularly inspected according to documented procedures, frequencies and criteria.

5.1.1.3 Raw materials and components

The specifications of all incoming raw materials and components shall be documented, as shall the inspection scheme for ensuring their conformity.

5.1.1.4 Non-conforming products

In the event of any non-conformity of any product, that product shall be placed into quarantine and action taken to rectify the cause of the non-conformity. Products may not subsequently be dispatched until the problem has been resolved.

5.1.1.5 Tests and frequencies

All the elements, requirements and provisions adopted by the manufacturer are documented in a systematic manner in the form of written policies and procedures. This production control system ensures that the product is in conformity with the European Technical Assessment (ETA).

5.2 Tasks for the Technical Assessment Body

5.2.1 Assessment of the performance of the construction product

Assessment of the concrete shuttering blocks and the EPS insulating blocks has been conducted under the responsibility by the assessment body (UBA_{tc}) in accordance with EAD 340024-00-0103. These assessment results should be used for the purposes of assessment of the performance of the construction product in accordance with Regulation (EU) N° 305/2011, Annex V, clause 1.6.

5.2.2 Assessment of the factory production control - Initial inspection and continuous surveillance

Assessment of the FPC is the responsibility of a Notified Body. An assessment shall be carried out on the required manufacturing steps of each manufacturing plant to demonstrate that the factory production control is in conformity with the ETA and any subsidiary information. This assessment is based on an initial inspection of the factory.

Subsequently continuous surveillance of factory production control is necessary to ensure continuing conformity with the ETA. This continuous surveillance is performed in accordance with this ETA, clause 5.1.1

It is recommended that surveillance inspections should be conducted at least twice a year.

6 References

As far as no edition date is given in the list of standards hereafter, the standard in the version at the time of issuing the European Technical Assessment, is of relevance.

ETAG 009	Non Load-bearing permanent shuttering kits/systems based on hollow blocks or panels of insulated materials and sometimes concrete.
EN 206-1:2013	Concrete - Specification, performance, production and conformity.
EN 1992-1-1	Eurocode 2: Design of concrete structures – Part 1-1: General rules and rules for buildings.
EN 13163	Thermal insulation products for buildings - Factory made expanded polystyrene (EPS) products – Specification.
EN ISO 6946	Building components and building elements - Thermal resistance and thermal transmittance - Calculation method.
EN ISO 10456	Building materials and products -- Hygrothermal properties -- Tabulated design values and procedures for determining declared and design thermal values.
EN ISO 13788	Hygrothermal performance of building components and building elements -- Internal surface temperature to avoid critical surface humidity and interstitial condensation -- Calculation methods.

UBAtc asbl is a non-profit organization according to Belgian law. It is a Technical Assessment Body notified by the Belgian notifying authority, the Federal Public Services Economy, SMEs, Self-Employed and Energy, on 17 July 2013 in the framework of Regulation (EU) No 305/2011 of the European Parliament and of the Council of 9 March 2011 laying down harmonised conditions for the marketing of construction products and repealing Council Directive 89/106/EEC and is member of the European Organisation for Technical Assessment, EOTA (www.eota.eu).

This European Technical Assessment has been issued by UBAtc asbl, in Sint-stevens-Woluwe, on the basis of the technical work carried out by the Assessment Operator, BCCA.

On behalf of UBAtc asbl,



Peter Wouters,
Director

On behalf of the Assessment Operator, BCCA, responsible for the technical content of the ETA,



Benny De Blaere,
Director general

The most recent version of this European Technical Assessment may be consulted on the UBAtc website (www.ubatc.be).

ANNEX 1: Drawings

I.1 Standard shuttering elements

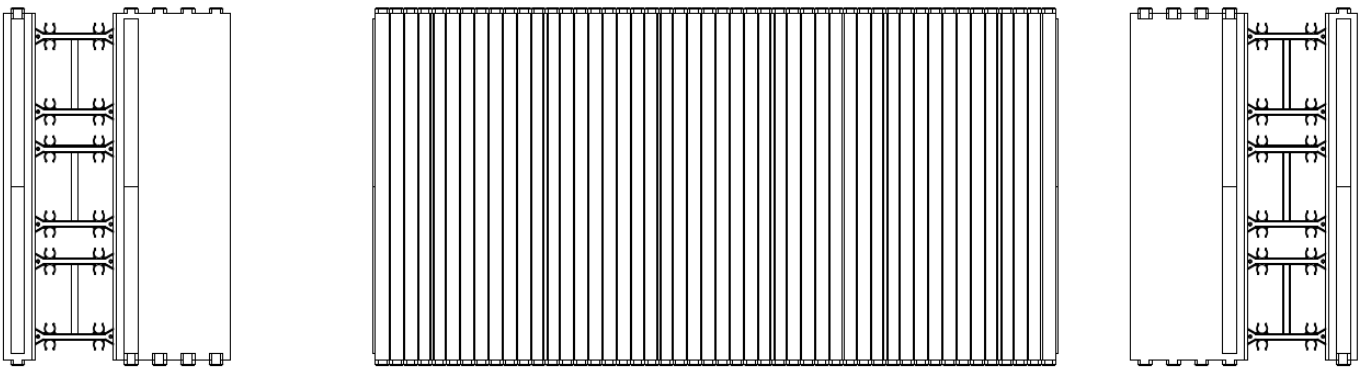
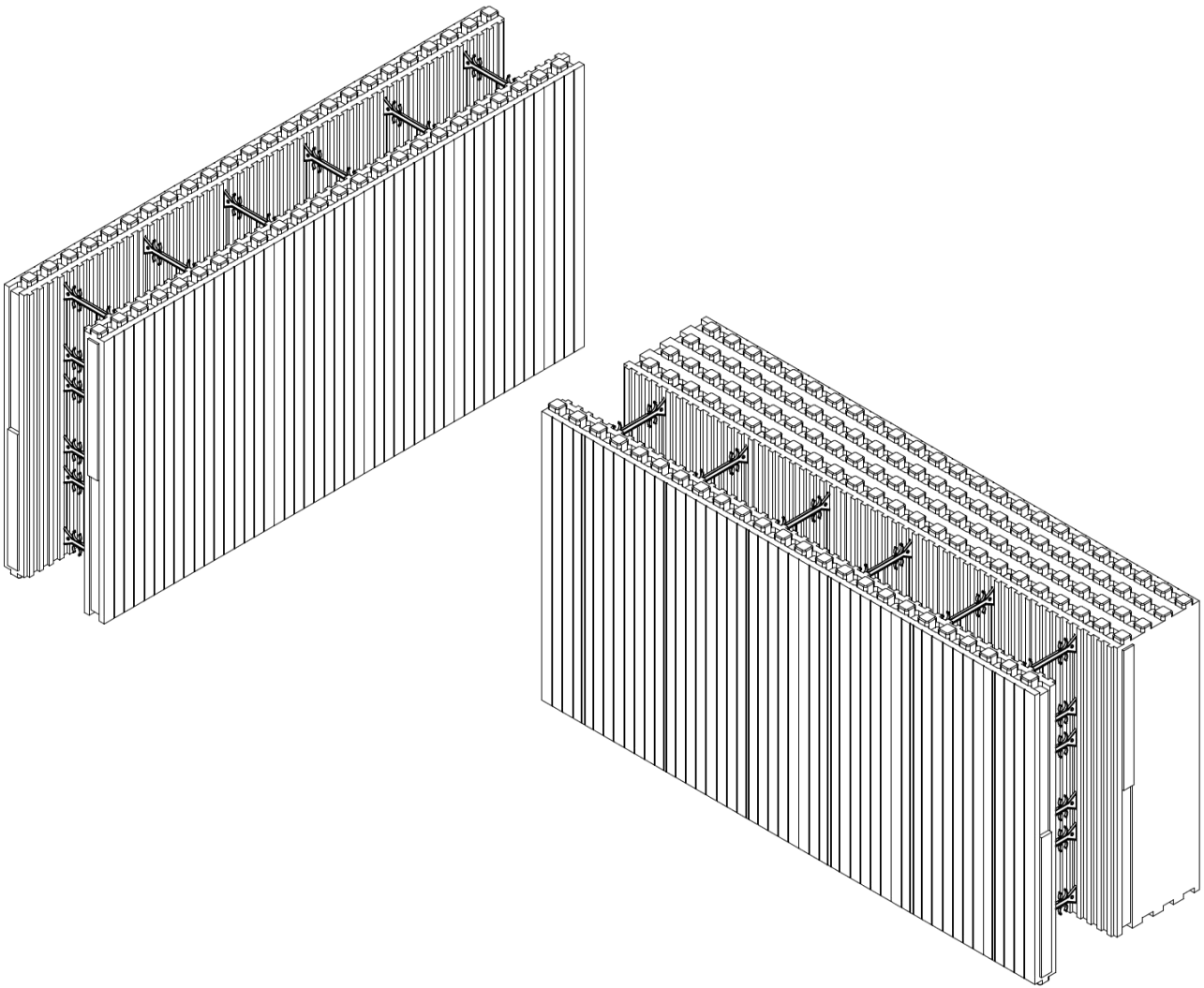

Green Isologic proposes four different blocks (Green Isologic EU, LE, PA or ZE) depending on the thickness of the external leaf.

Green Isologic EU

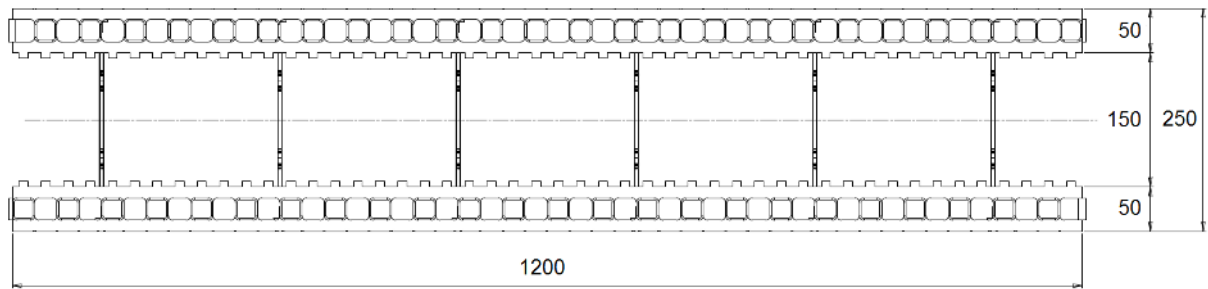

Green Isologic LE

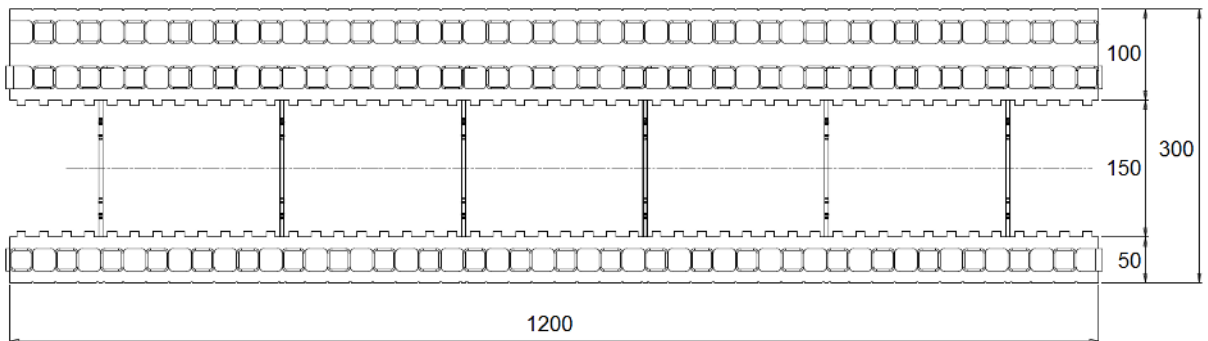

Green Isologic PA

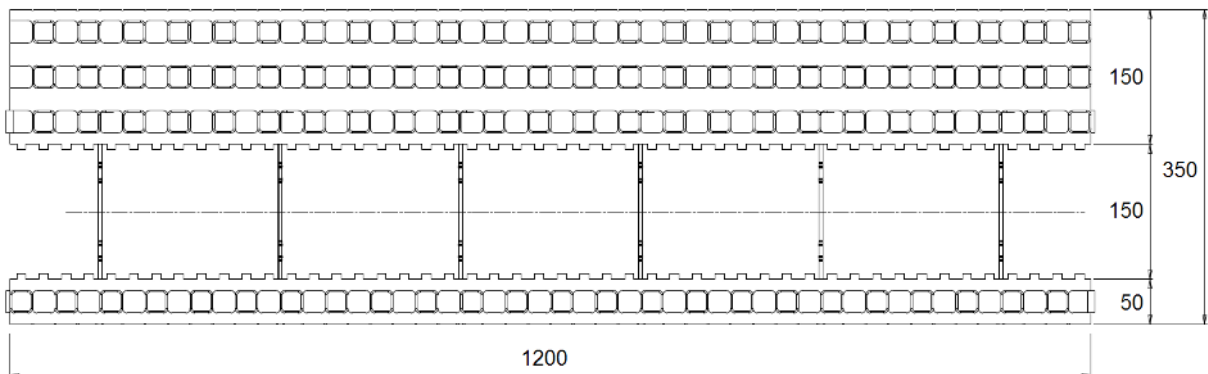

Green Isologic ZE

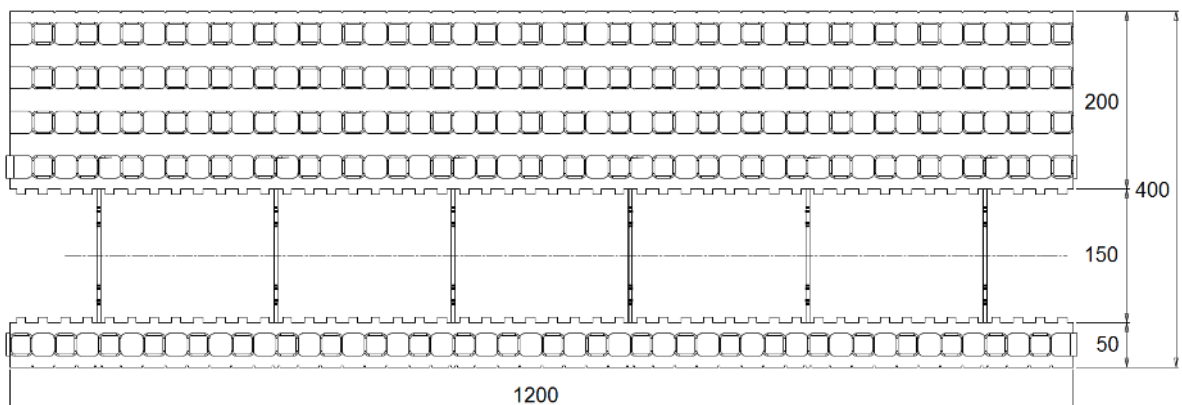

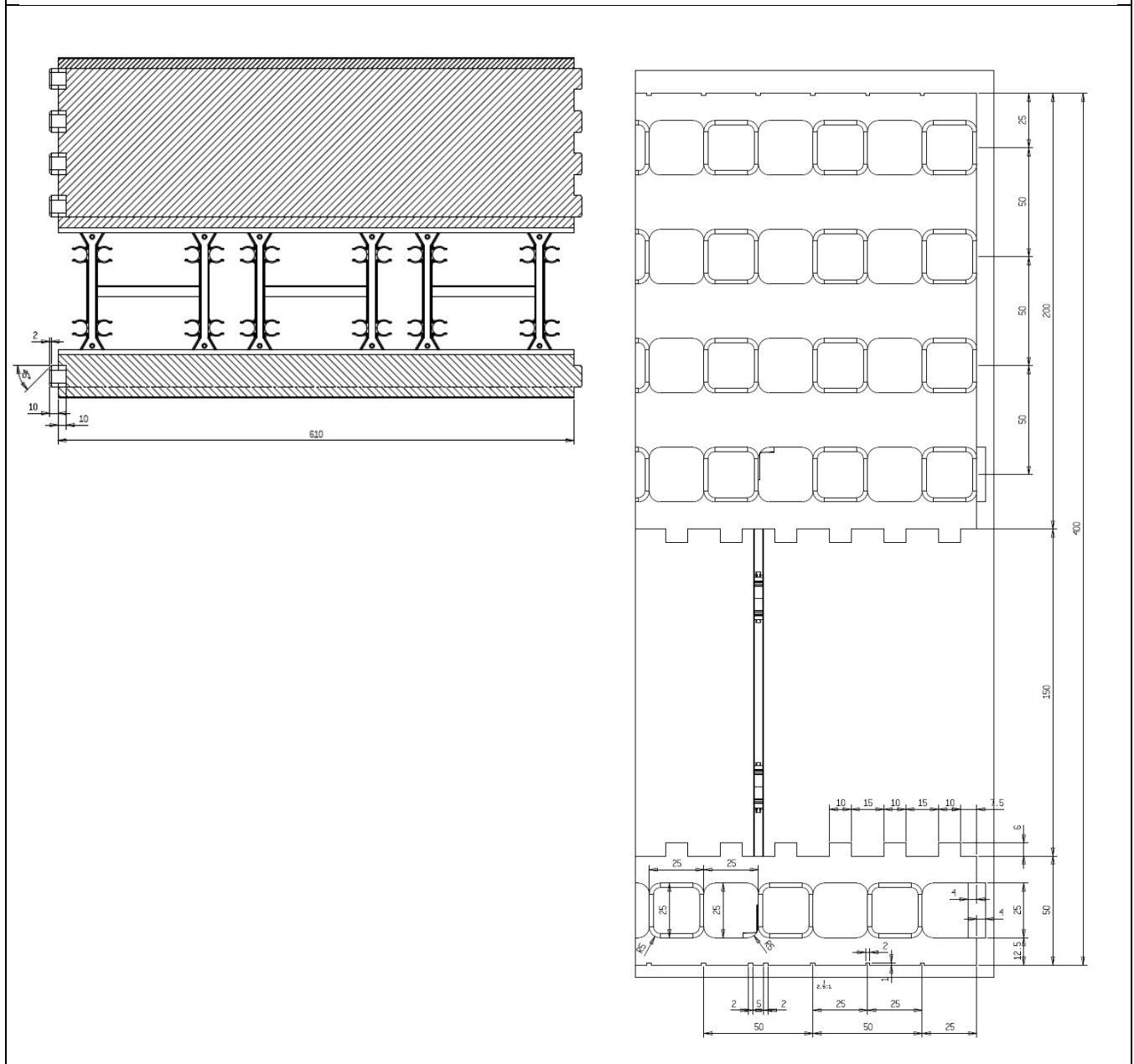
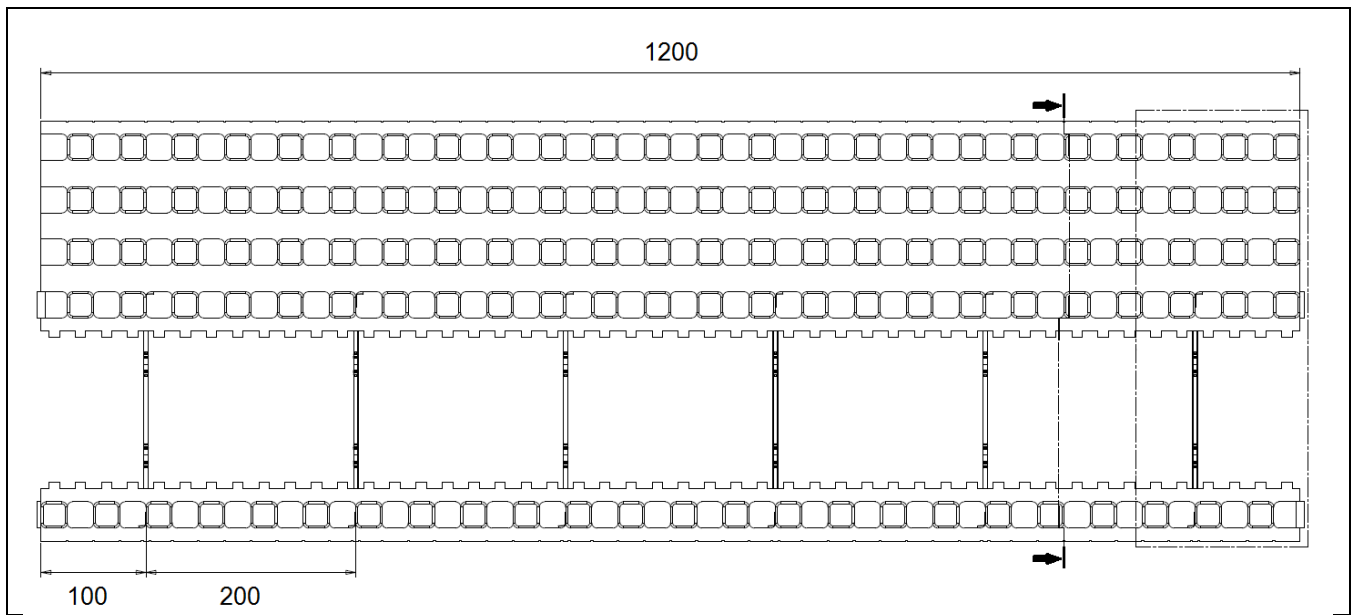

I.2 Corner elements

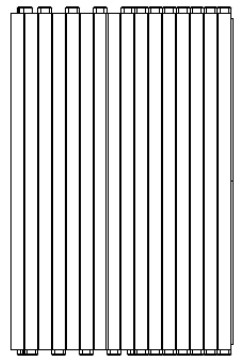
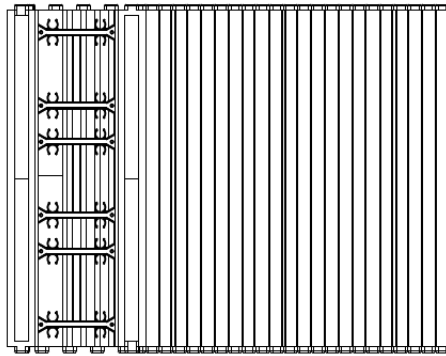
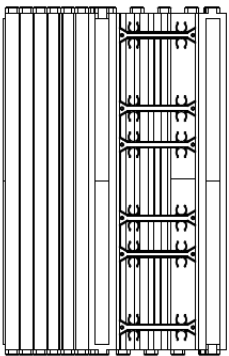
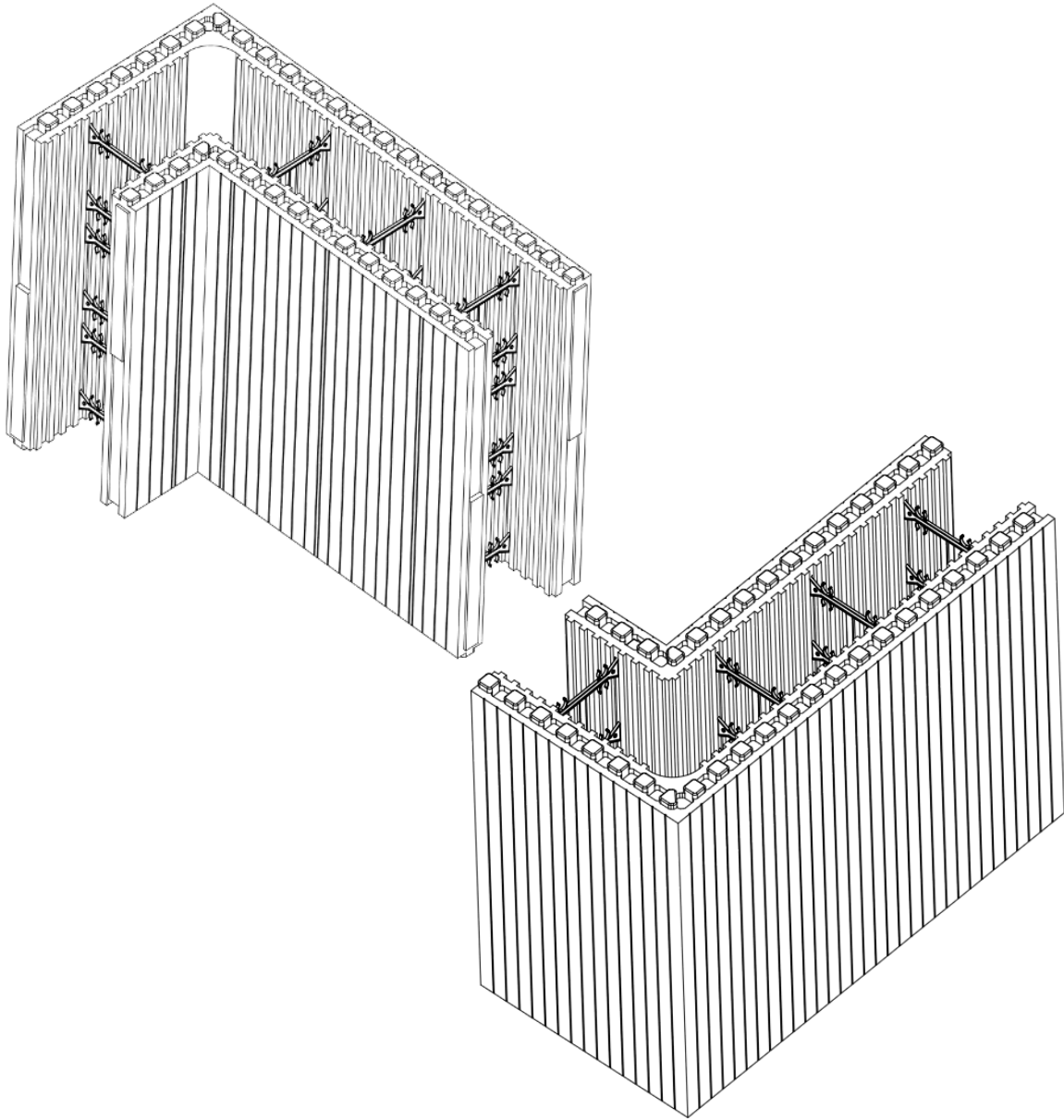

Green Isologic EU

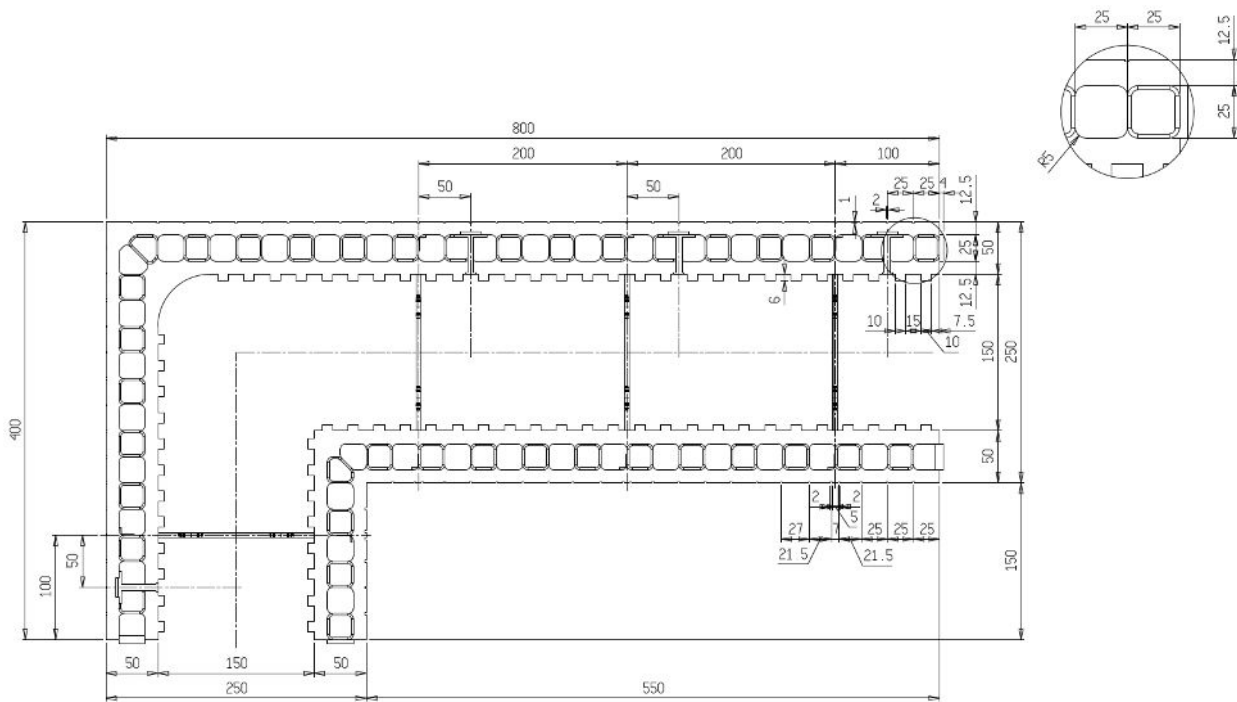

Green Isologic LE

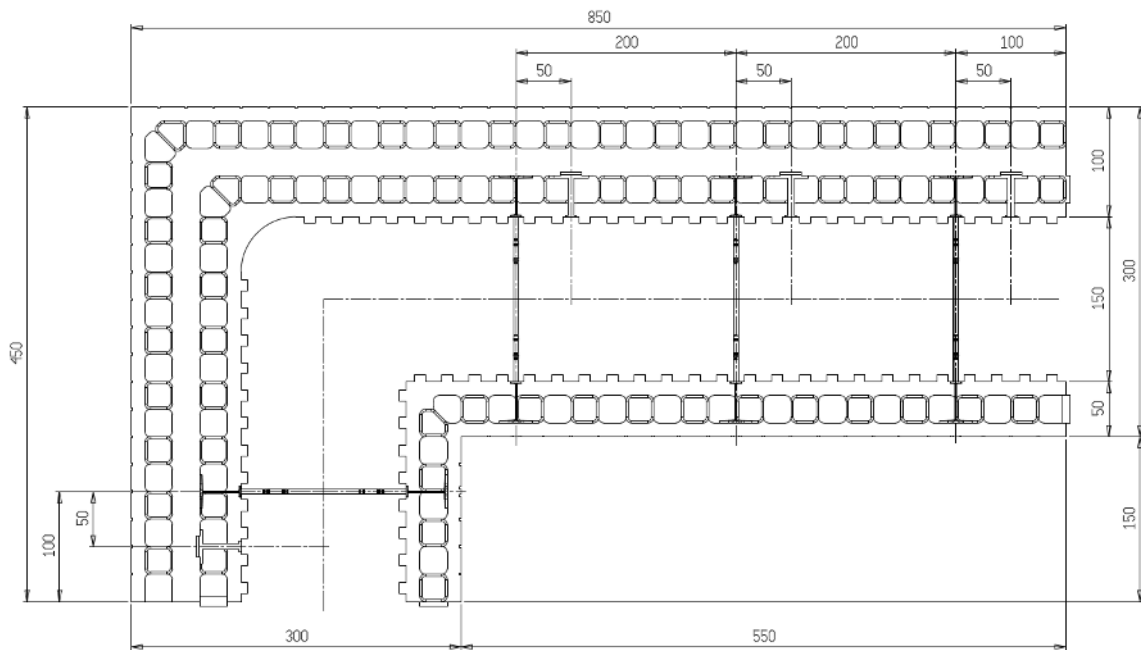

Green Isologic PA

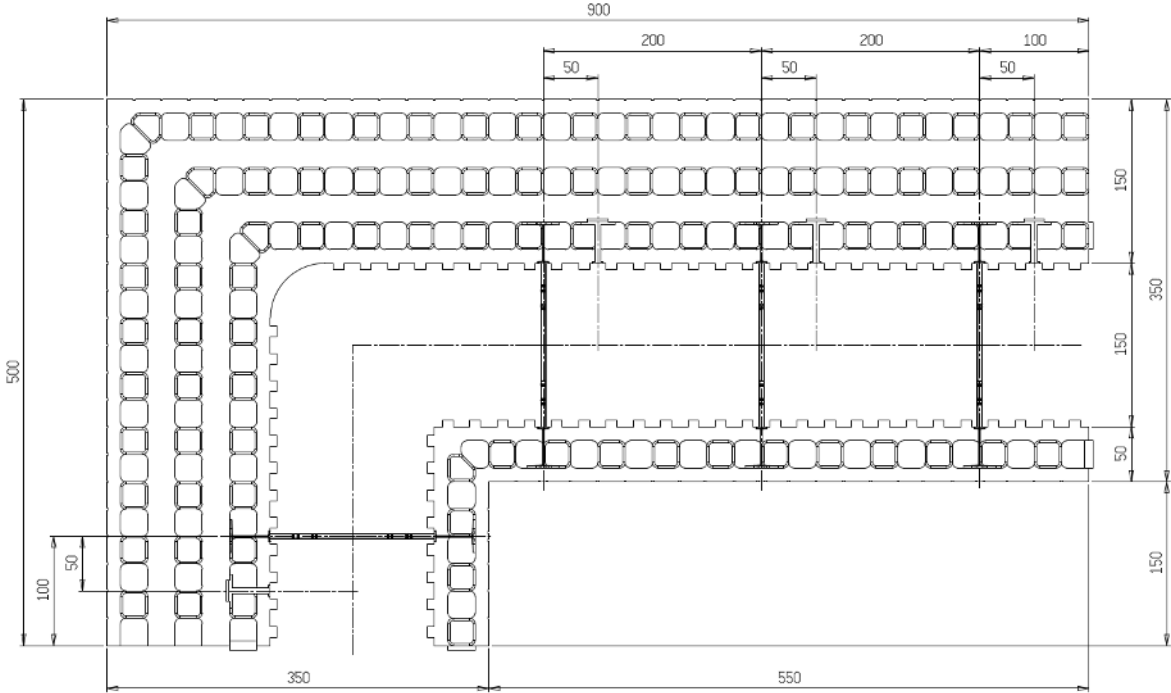

Green Isologic ZE

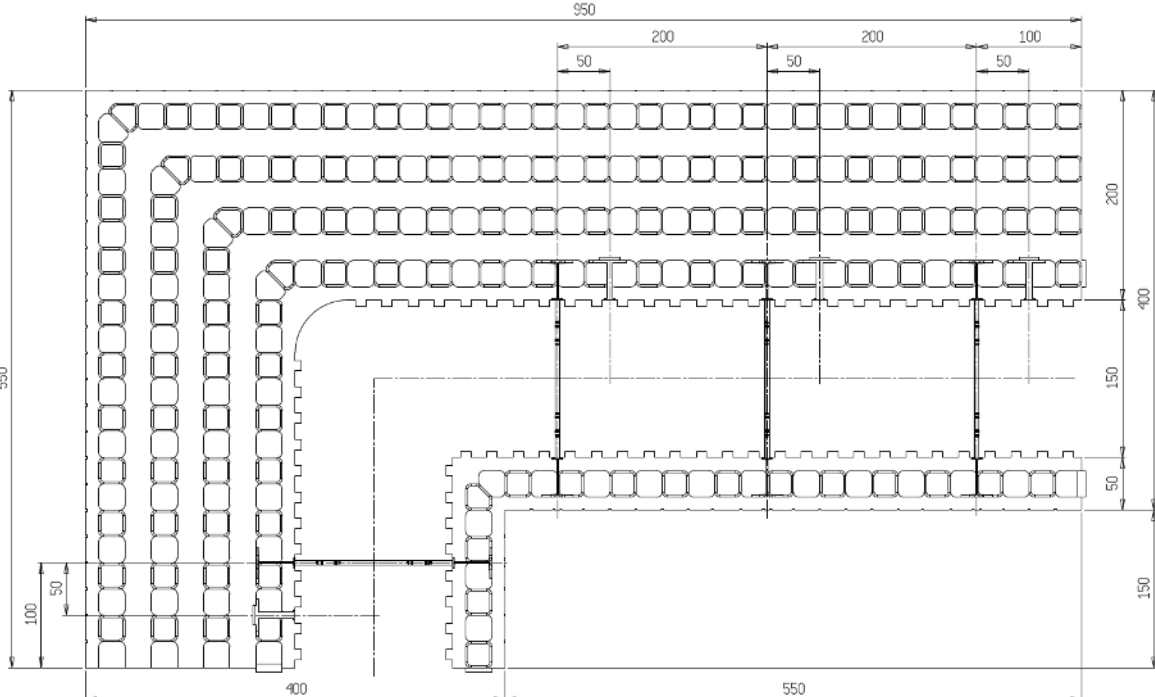

I.3 Accessory parts

Lintel bottom leaf

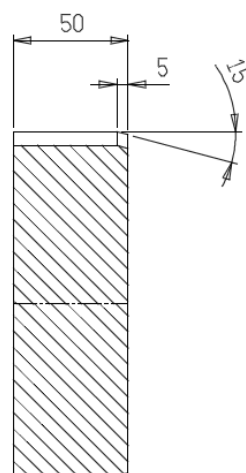
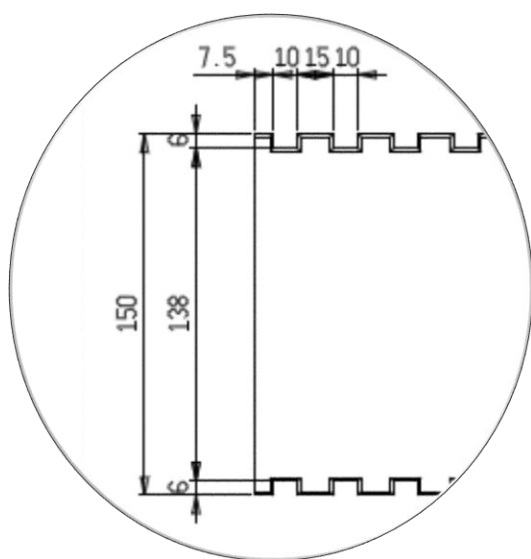
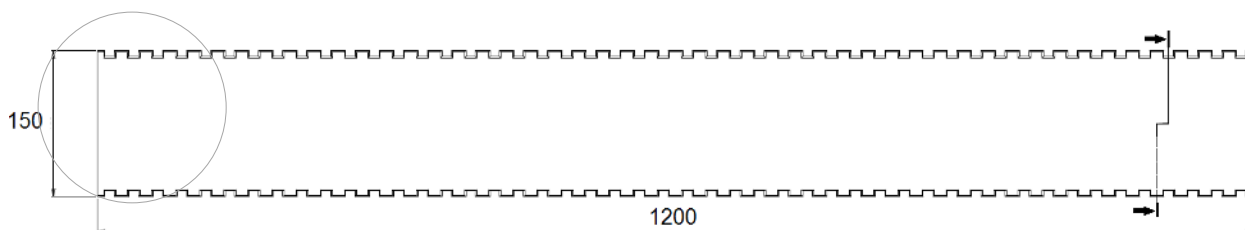
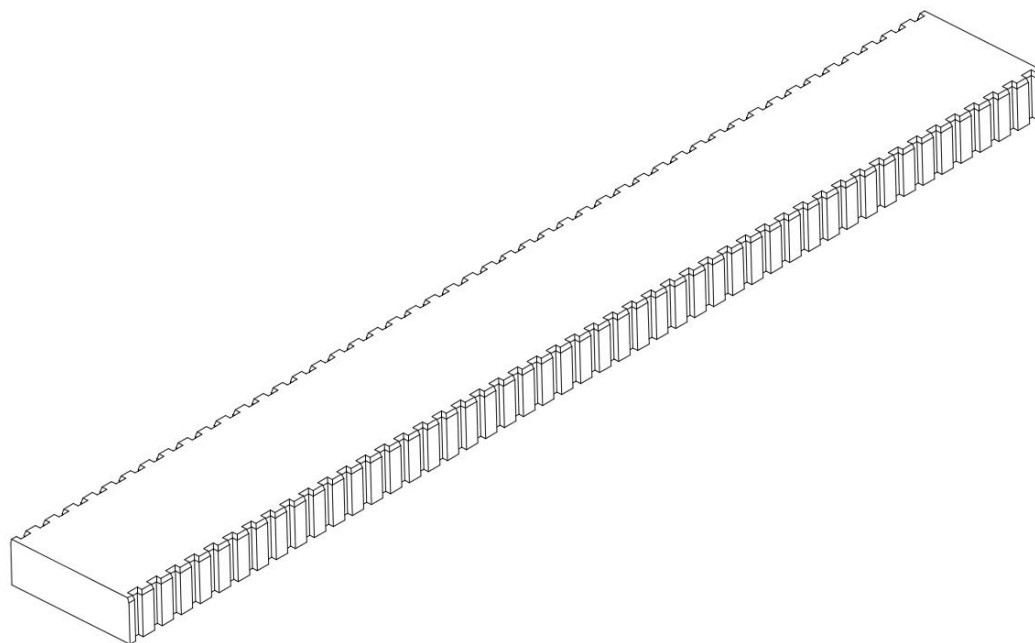

End leaf

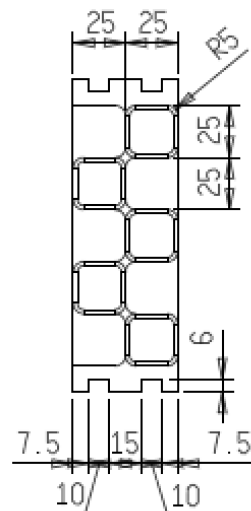
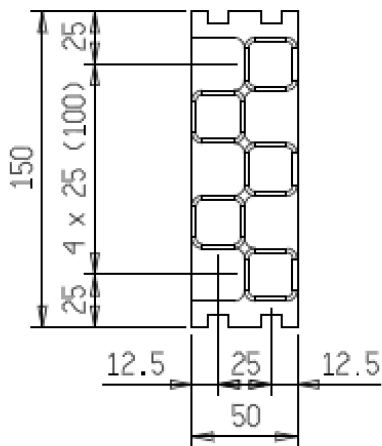
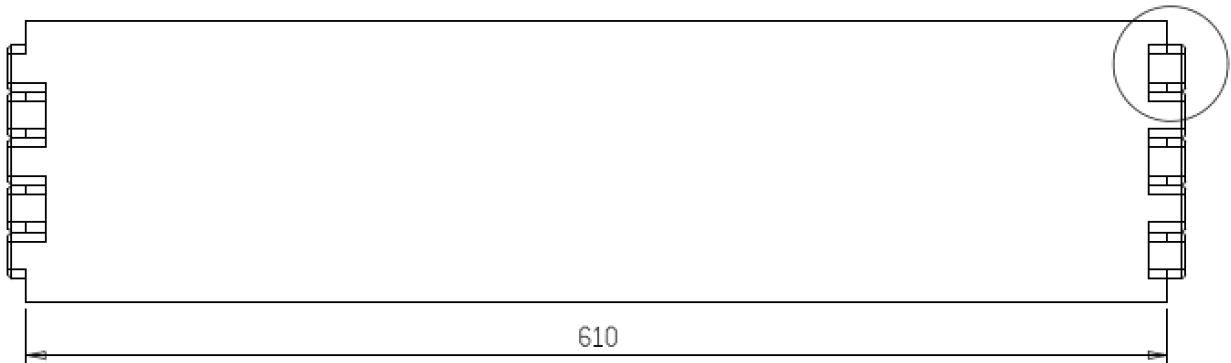
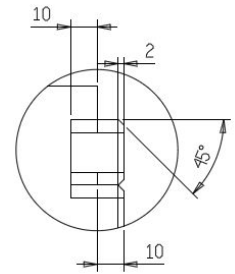
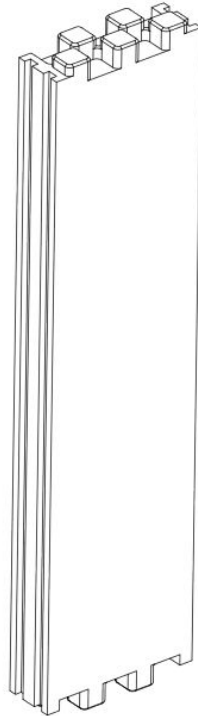
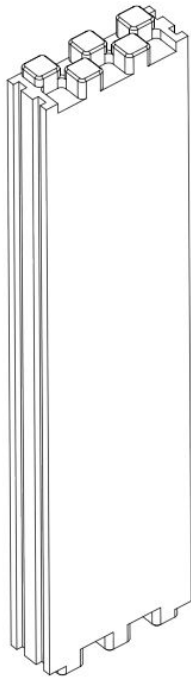
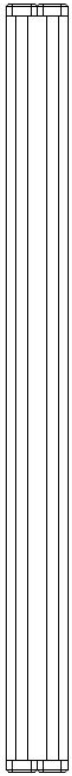

Annex II Assembly details

This annex provides details about the assembly of the different building components with the shuttering elements.

Foundation + Floor/External wall

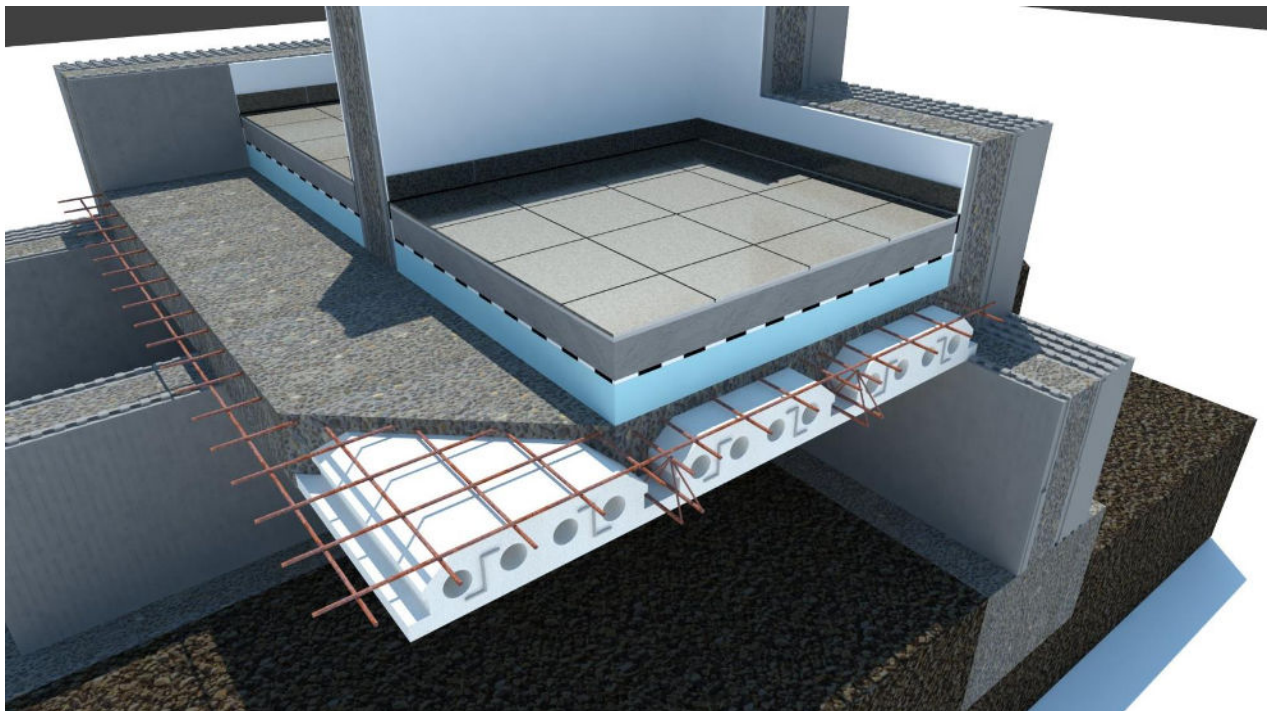
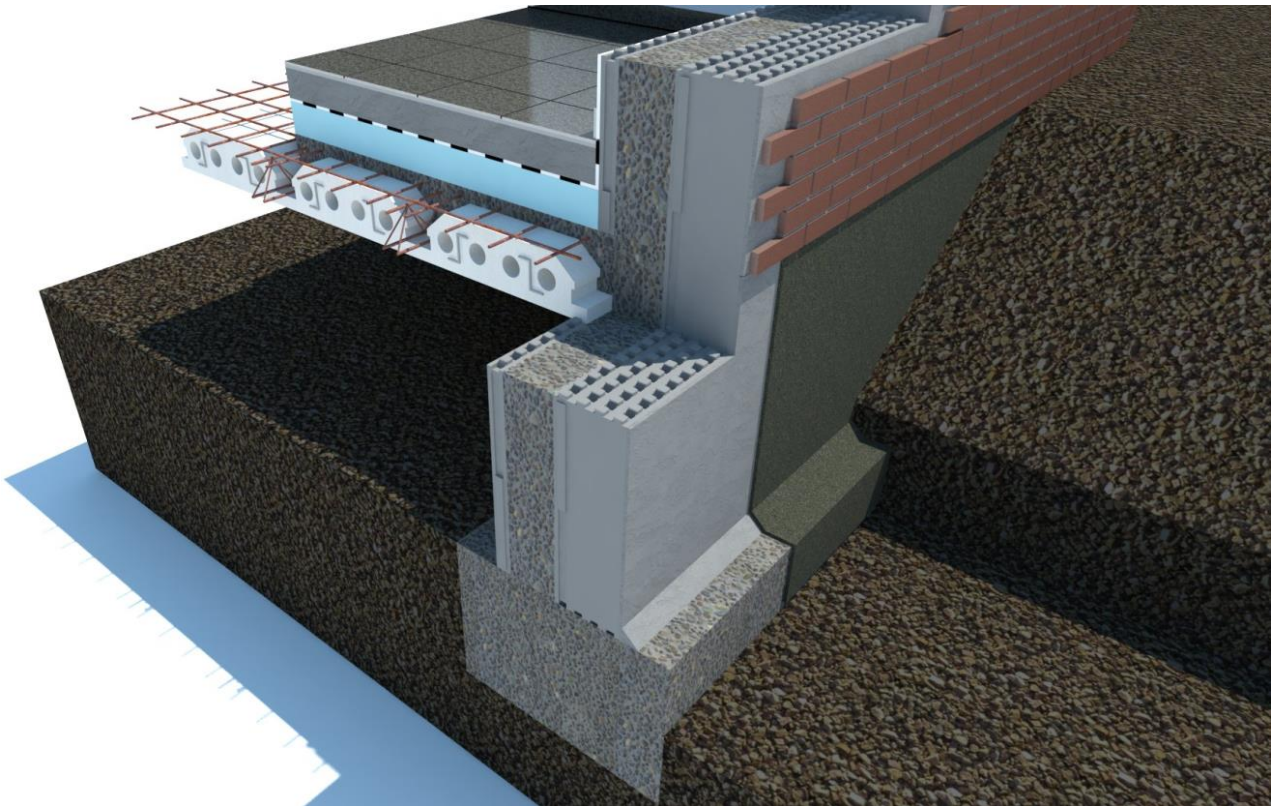

External wall/External wall

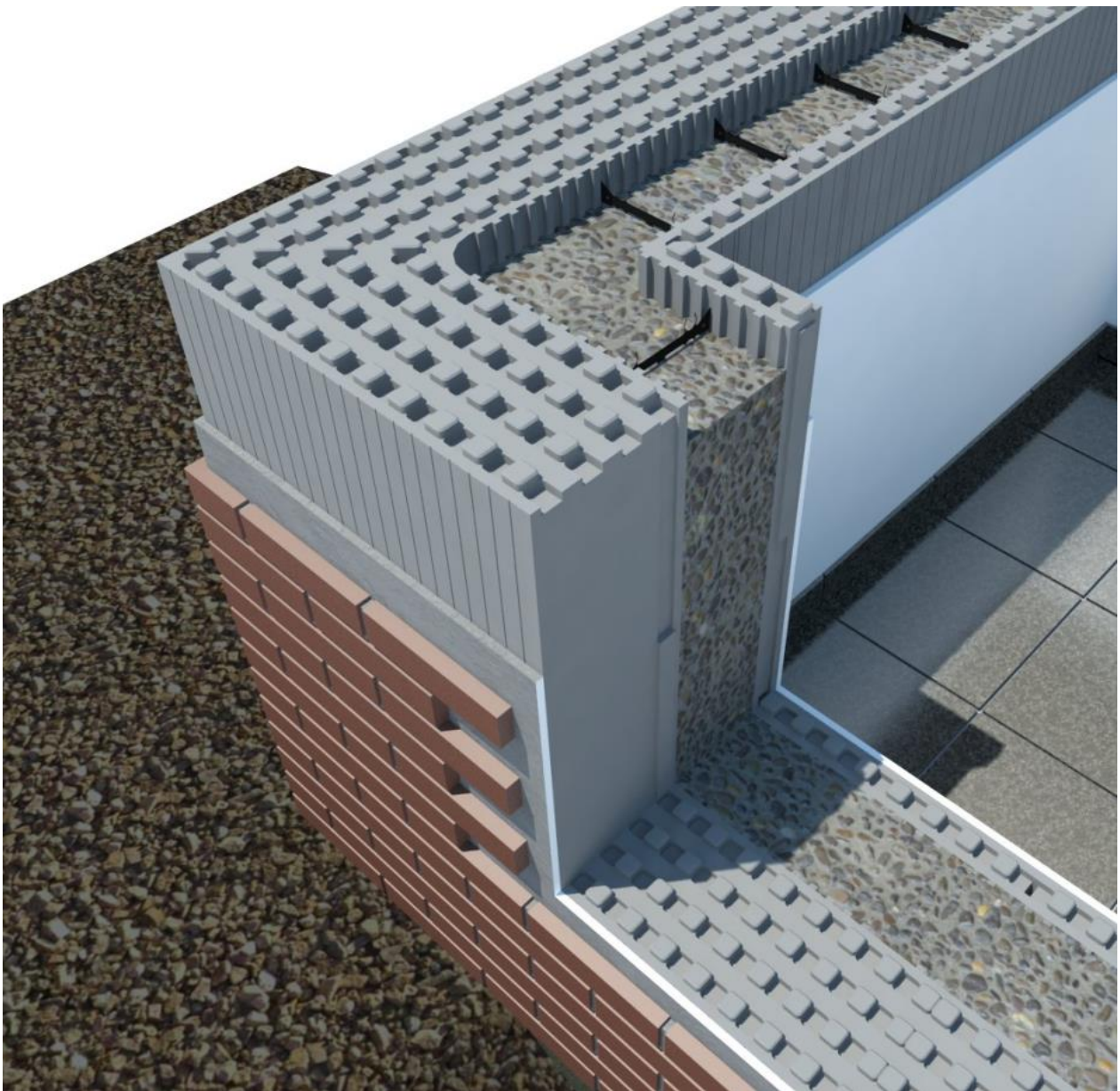

Internal wall/External wall

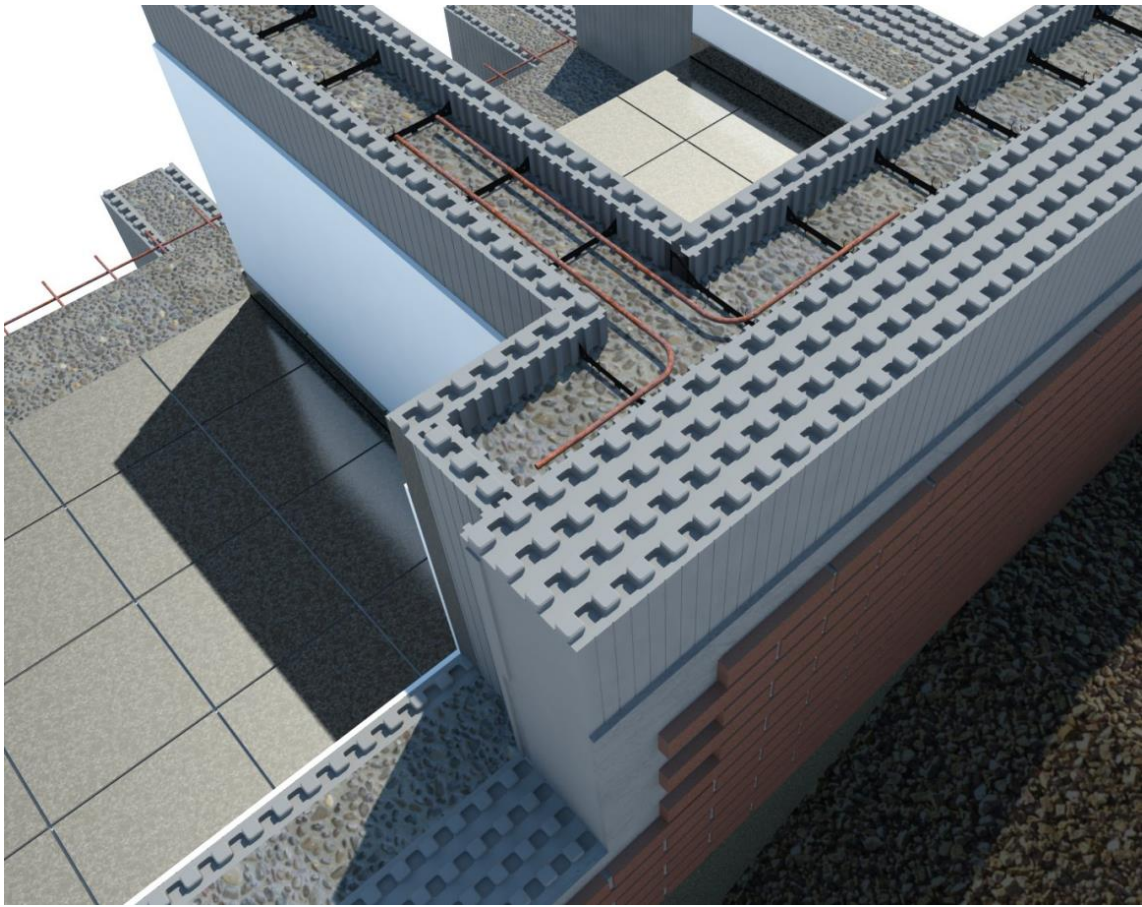

For the connection between an inner wall and an outer wall, it is necessary to cut and remove a portion of the block (inner leaf of the outer wall) to obtain a monolithic wall. Steel reinforcement can be expected to strengthen the connection.

External wall/Inclined roof

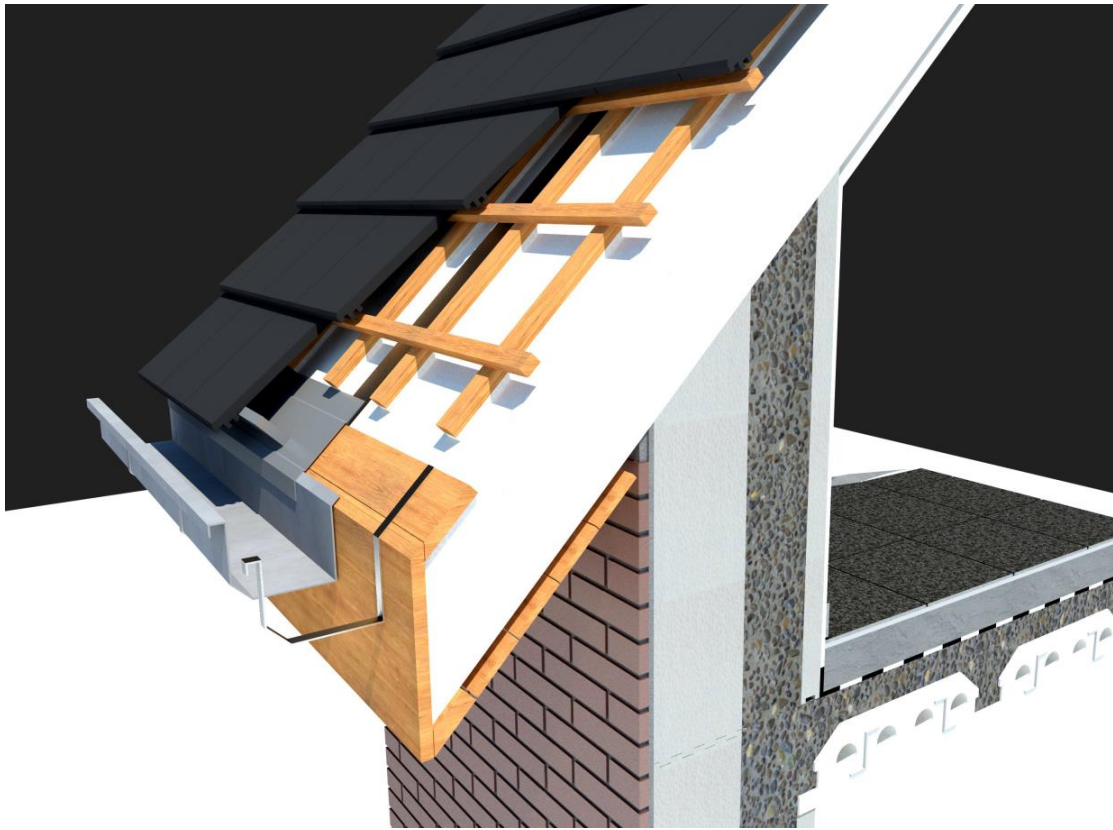

External wall/Flat roof

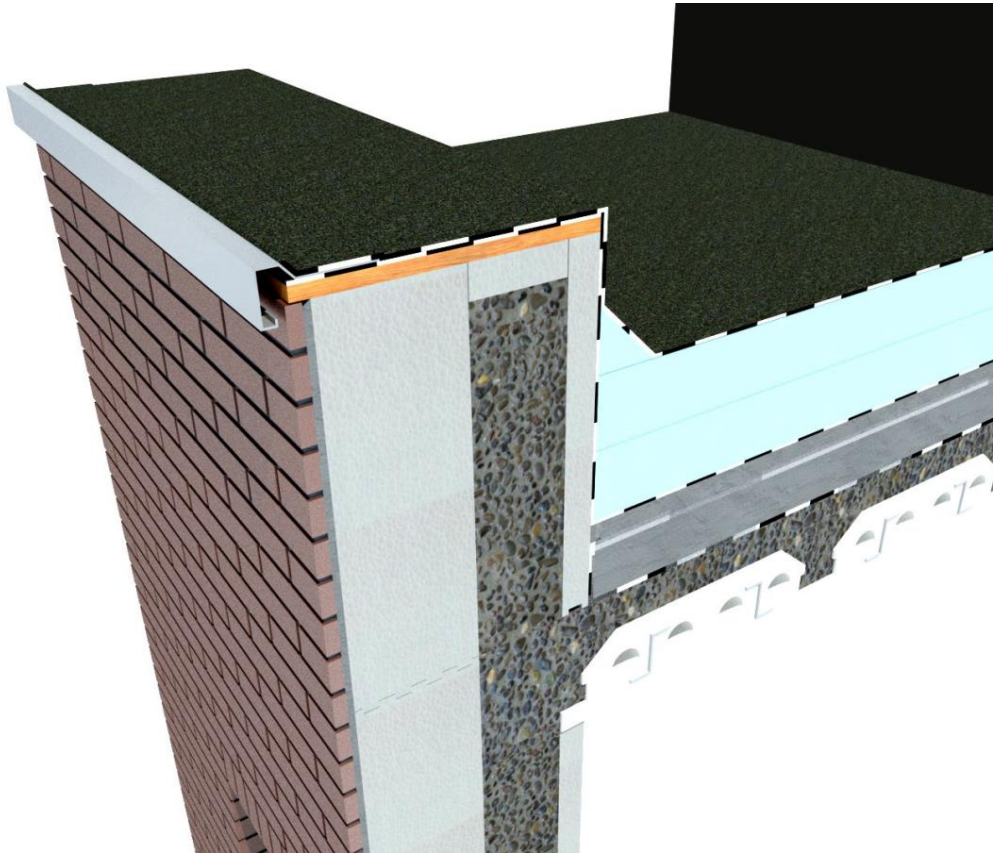

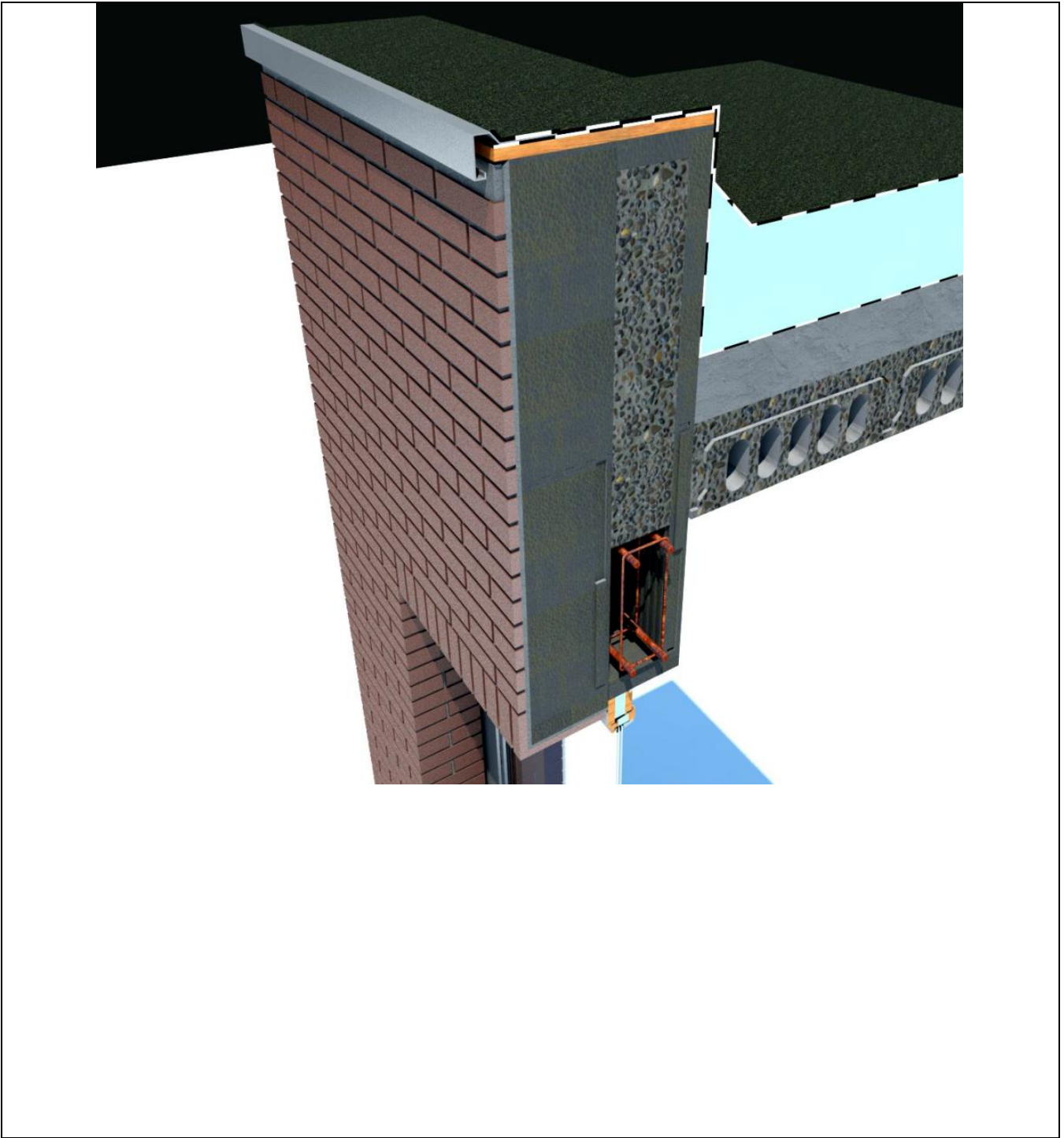

External wall/windows-doors

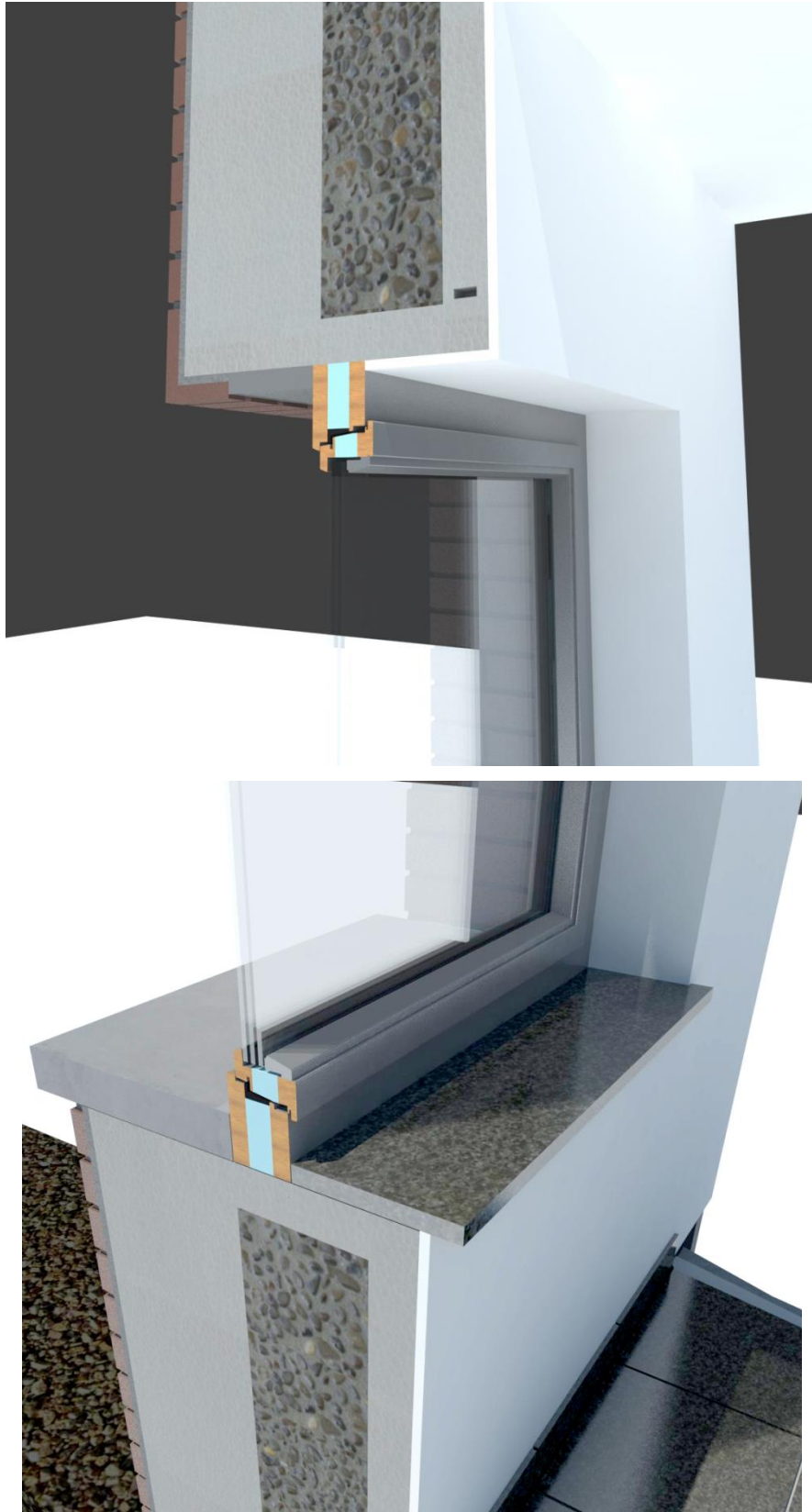

Lintel

In case of EPS selfsupporting panels

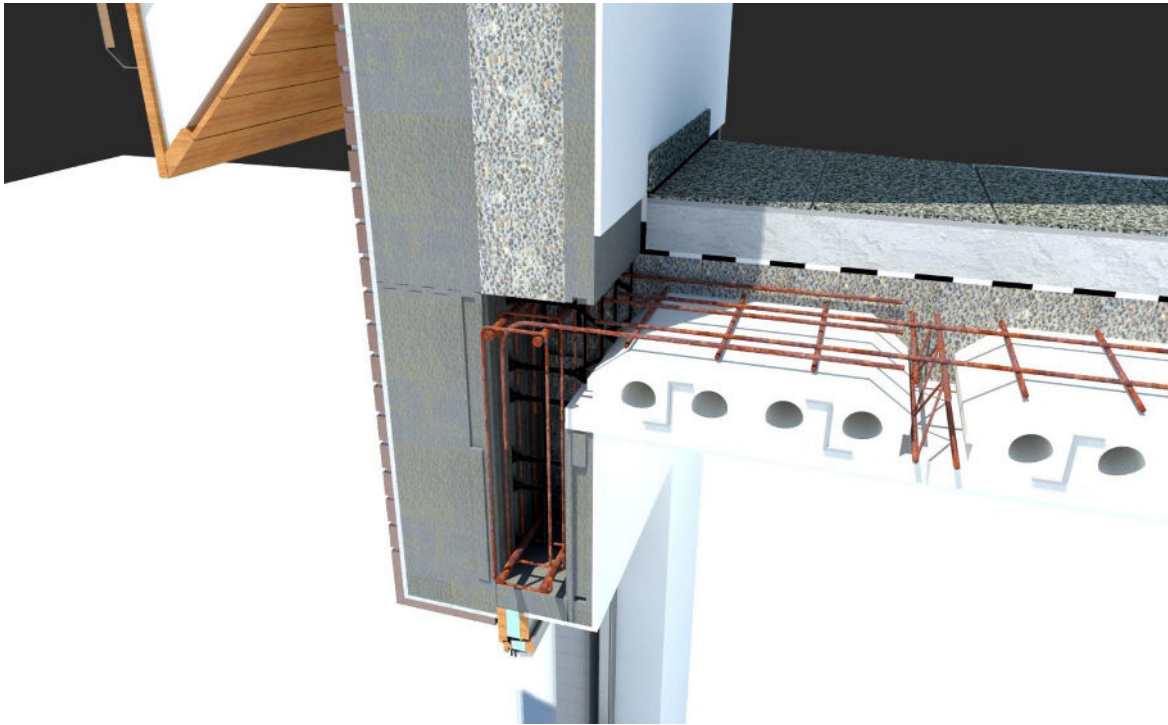

In case of precast concrete hollow core slabs

